

# SmallRig

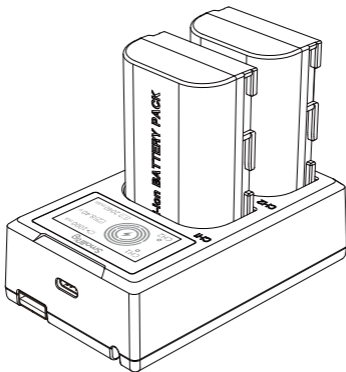

## Camera Battery and Charger Kit

LP-E6NH

User Manual

# Foreword

Thank you for purchasing SmallRig products.

## Warnings

- Please read this User Manual carefully before using the product.
- Keep this User Manual properly. If other users want to use this product, give this User Manual with the product.
- Note all the warnings and follow all the instructions provided in this User Manual.
- Do not disassemble or damage the product. If the battery is swollen, deformed or gets wet, immediately stop using the product.
- Avoid dropping the product. Do not use it in excessive temperature or short circuit situation.
- Keep out of reach of children.
- When the battery is not in use for a long time, please charge and discharge the battery every 3-month, and provide it with approximately 60% of the electric quantity to prolong its lifetime.
- Before leaving the factory, the State Of Charge(SOC)of battery  $\leq$  30% of its rated design capacity.



Do not disassemble the product or replace its battery. If you have any questions, please contact the seller to apply for after-sales service.

## Intended Use

- Read this manual carefully, especially the "Important Note" section.
- Use and store this product in the ambient conditions specified in this manual.
- Failure to use the product in accordance with this manual or within the specified operating and storage conditions will be considered as a breach of warranty.

## Specifications

Battery Type	Lithium-ion Battery
Battery Parameter	2040mAh 7.2V 14.69Wh
Battery Charging Limited Voltage	8.4V
Charger Input	USB-C: 5V = 2.1A (Min)
	USB-A: 5V = 2.1A (Min)
Charger Output	8.4V = 1000mA (Single)
	8.4V = 1000mA (Dual)
Operating Environment Temperature	0°C ~ 40°C

• The data are measured by SmallRig Lab but may vary based on specific circumstances.

## Battery Instructions

1. Please fully charge the battery pack when using for the first three times.
2. Battery pack would be better charged on SmallRig charger or the original charger.
3. For more information, please refer to the battery part in your camera manual.

## Charger Instructions

1. If there are no batteries plugged into the charger while powering on, the lightning icon stays on constantly, the lightning icon stays on constantly.  
(As shown below)



2. When charging through CH1 and CH2 slots at the same time, it displays the real-time charging information of each slot every 5 seconds in turns, such as charging current, battery voltage, and battery capacity (mAh). If the circle below CH1 or above CH2 stays on, it means that there is a battery in the slot. When the battery is fully charged, the circle indicator turns off. (As shown below)

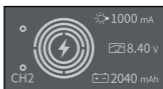
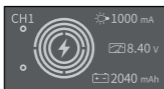

3. In the testing of output short circuit and the bad battery, the each-second flashing of a lightning icon every second indicates a bad battery or short-circuit condition of the corresponding channel (as shown below). In that case, unplug the power cord and then plug it back, and the battery will be recharged again.



4. Put batteries into the slots when there is no power supply. It displays information such as CH1 or CH2, the lighting icon and the real-time voltage of the battery in the corresponding slot. (As shown below) All the indicator lights will be off in 5 seconds.



5. The battery level icon flashes every second. Each circle represents a 25% battery capacity. That is, when the first circle lights up, the battery is charged 25%; when all the four circles are on, the battery is fully charged. (As shown below)



# SmallRig

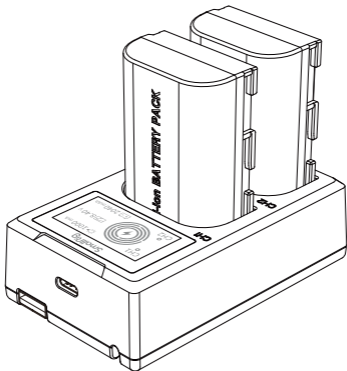

## 相机电池充电套装

LP-E6NH

用户手册

# 前言

感谢您购买SmallRig产品。

## 重要提示

- 请认真阅读本用户手册。
- 请妥善保管用户手册。将产品交给他人使用时，请务必附带本用户手册。
- 请注意所有警告提示并遵循用户手册的所有指令。
- 请勿拆卸或损伤本产品，若该电池膨胀、变形或进水，请立即停止使用。
- 请勿跌落或在高温、短路情况下使用本产品。
- 请将本产品放置在儿童不能接触的地方。
- 电池在长时间储存不用时，应在3个月内进行一次充放电维护，并恢复60%左右的带电量，以延长电池的使用寿命。
- 电池在出厂时的荷电量(SOC)  $\leq$  30%额定设计容量。



请勿拆卸产品，如您怀疑产品有任何问题，请联系购买平台，申请售后处理。

## 设备使用规范

- 请仔细阅读用户手册，特别是“重要提示”部分。
- 请在用户手册规定的环境条件下使用或保存本产品。
- 如不按照用户手册使用产品，或不遵守规定的工作和保存条件，将被视为违规使用。

## 产品参数

电池类型	锂离子电池
电池参数	2040mAh 7.2V 14.69Wh
电池充电限制电压	8.4V
充电器输入	USB-C: 5V=2.1A (最小值)
	USB-A: 5V=2.1A (最小值)
充电器输出	8.4V=1000mA (单充)
	8.4V=1000mA (双充)
工作环境温度	0°C ~ 40°C

\* 数据由 SmallRig 实验室测定值，但因客观环境改变，数据略有偏差。

## 电池使用说明

1. 前三次使用时请对电池长时间足量充电。
2. 使用SmallRig充电器或原装充电器充电，效果更佳。
3. 其他信息请参阅所使用机型说明书中电池部分。



## 充电器使用说明

1. 接通电源，不装电池，闪电图标常亮。（如下图）



2. 两个槽CH1、CH2同时充电，屏幕以每5秒频率切换显示相对应槽位的充电电流、电池电压、电池mAh等实时充电信息。CH1下方圆圈与CH2上方圆圈为槽位内有电池充电则该圆圈图标常亮，若槽内电池充满，则对应的圆圈熄灭。（如下图）

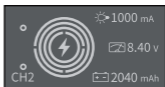
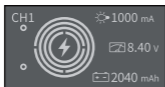

3. 输出短路和坏电池检测显示，相对应的通道闪电符号以1S一次的方式闪烁，表示此通道电池为坏电池或通道短路，（如下图）当出现闪电符号闪烁时必须重新插拨电源后，方可恢复充电模式。



4. 不接电源，接入电池，显示相对应的电池槽位内的CH1、CH2、闪电图标及电池实时电压。（如下图）亮5S后全部熄灭。



5. 电量图标以每1秒频率闪烁，第一圈亮为25%，第二圈亮为50%，以此类推，第四圈亮为100%电池充满。（如下图）

