

# SmallRig

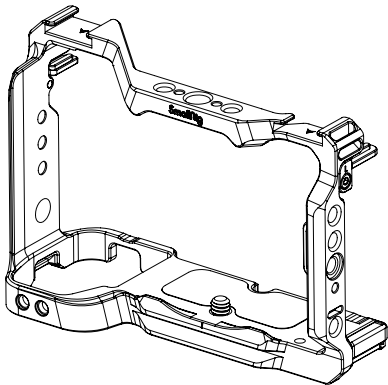

## Cage for Sony ZV-E1

User Manual

- Thank you for purchasing SmallRig's product.
- Please read this Operation Guide carefully.
- Please follow the safety warnings.

## In the Box

Cage × 1

## Product Details

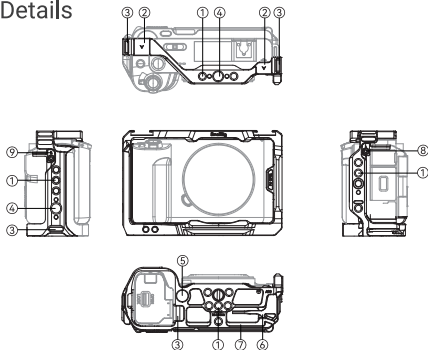

- ① 1/4"-20 Threaded Hole
- ② Cold Shoe Mount
- ③ Strap Slot
- ④ ARRI 3/8"-16 Locating Hole
- ⑤ QD Socket

- ⑥ Dual-Head Wrench
- ⑦ Arca-Swiss Quick Release Plate
- ⑧ Left Side Lock Adapter
- ⑨ Right Side Lock Adapter

## Installation Introduction

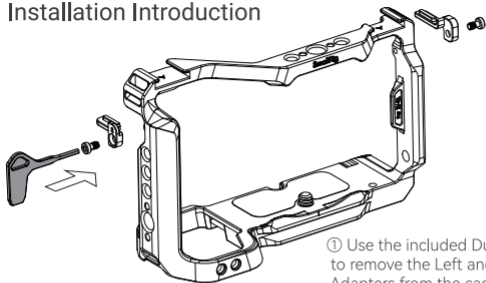

① Use the included Dual-Head Wrench to remove the Left and Right Side Lock Adapters from the cage.

② Remove the camera lens and place the camera into the cage from the back to the front.

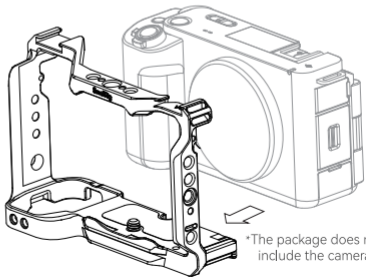

\*The package does not include the camera.

③ Use the Dual-Head Wrench to secure the bottom 1/4"-20 screw, but do not fully lock it.

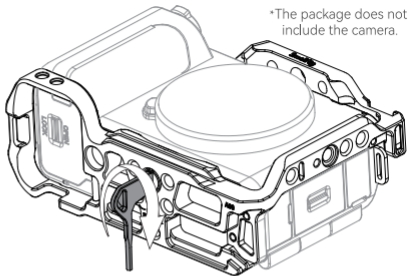

\*The package does not include the camera.

\*The package does not include the camera.

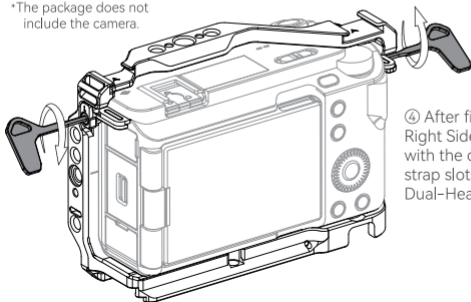

④ After fixing the Left and Right Side Lock Adapters with the camera shoulder strap slots, lock them by the Dual-Head Wrench.

\*The package does not include the camera.

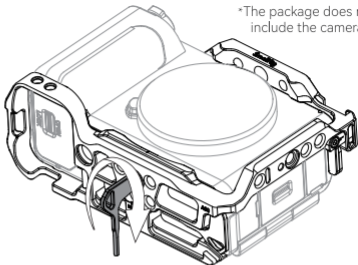

- ⑤ Use the Dual-Head Wrench to lock the bottom 1/4"-20 screw.

## Compatibility

Sony ZV-E1

## Specifications

Product Dimensions: 136.2 × 89.8 × 53.0mm

Product Weight: 128.0 ± 5.0g

Material(s): Aluminum Alloy, Stainless Steel

# Service & Warranty

---

Please keep your original receipt and guarantee card. Be sure the dealer has written on it the date of purchase and SN of the product. These are required for warranty service.

## After-sale Warranty Terms

SmallRig products are entitled to warranty services as of the date of payment.

- Electronic products (except V mount battery): 1-year warranty.
- V mount battery: 2-year warranty.
- Non-electronic products: 2-year warranty.

Note: In case of any conflict between our warranty period policy and applicable laws and regulations of the country / region where the products are sold, the latter shall prevail.

## This Warranty Does Not Cover

1. If users fail to adhere to the "Operating Instruction" or any "Warnings" stated in the user manual, resulting in a quality failure, it falls outside the scope of warranty coverage.
2. The product identification or SN label is removed or defaced in any way.
3. Product damage caused by problems not attributable to the quality of the products such as improper use of the products.
4. Product damage caused by unauthorized modification, disassembly, repair and other acts.
5. Product damage caused by fires, floods, lightning and other force majeure factors.

## Warranty Mode

- For the products within the scope of warranty, SmallRig will repair or replace them on the basis of specific failures; the repaired / replaced products / parts are entitled to the remaining part of the original warranty period.

## Contact Information

- You're advised to contact the online customer service personnel of corresponding shopping platform and submit a repair service application.
- You may also apply for repair service through SmallRig's service email,  
Service Email: [support@smallrig.com](mailto:support@smallrig.com)

## Guarantee Card

Serial No.	
Item Name	
Purchase Date	
User Name	
Mobile	
Address	
Receipt	

EC	REP	ProInx GmbH Brehmstr.56,40239 Duesseldorf Germany eu@eulinx.eu
----	-----	--

UK	REP	ProInx Global LTD 27 Old Gloucester Street London, WC1N3AX, UK eu@eulinx.eu
----	-----	---

Manufacturer: Shenzhen Leqi Innovation Co., Ltd.

Add: Rooms 103, 501 and 601, Building 5, Fenghe Industrial Park, Nos. 1301-50 Guangguang Road, Longhua District, Shenzhen, Guangdong, China.

Consignor: Shenzhen LC Co., Ltd.

Add: Rooms 602, Building 5, Fenghe Industrial Park, No. 1301-50 Guangguang Road, Xinlan Community, Guanlan Street, Longhua District, Shenzhen, Guangdong, China.

**CE RoHS**



Made in China



WE ARE HERE FOR YOU

服务与支持



ETICHETTATURA AMBIENTALE

ENVIRONMENTAL LABELING