

版本	更新内容	更新日期
v0.0	量产图纸	2024.06.03

尺寸: 74 × 105mm

材质: 100g书纸, 单色印刷, 风琴折

第一封面: 英文版

"■" C:0 M:0 Y:0 K:90

105mm

74mm

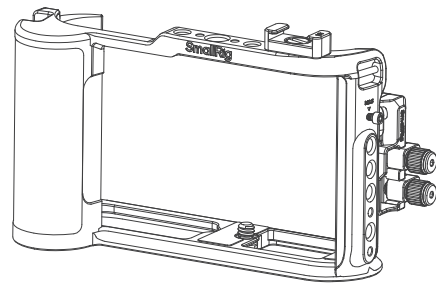

Cage Kit for Leica Q3 Camera
徕卡 Q3 拓展框套件

Operating Instruction / 操作指引

Thank you for purchasing SmallRig's product. 感谢您购买 SmallRig 产品。

Please read this Operation Guide carefully. 使用本产品之前, 请仔细阅读操作指引。

Please follow the safety warnings. 请注意所有警告提示并遵循使用操作指引的所有指令。

In the Box / 包装清单

Cage 拓展框	× 1	Handgrip Support 手握支撑	× 1
Cold Shoe 冷靴安装座	× 1	Operating Instruction 操作指引	× 1
1/4"-20 Screw 1/4"-20 螺丝	× 1	Guarantee Card 保修卡	× 1

Cage Installation Instruction / 拓展框安装步骤

Step 1: Put the camera into the cage from back to the front and secure the camera with one 1/4"-20 screws at the base.

第一步: 将相机从后往前放入相机拓展框, 通过底部一颗1/4"-20 螺丝与机身锁紧固定。

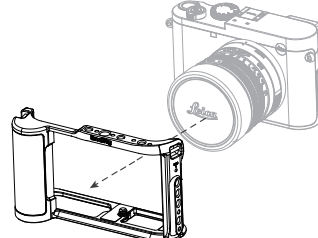

* The package does not include the camera
* 相机机身需另购

Step 2: Remove the 1/4"-20 screw at the left of the cage, and then pass the M2.5 screws through the shoulder strap holes on left side of the camera and tighten them onto the cage.

第二步: 取下拓展框左侧的M2.5 螺丝, 然后将M2.5 螺丝分别穿过相机左侧肩带孔与拓展框锁紧固定。

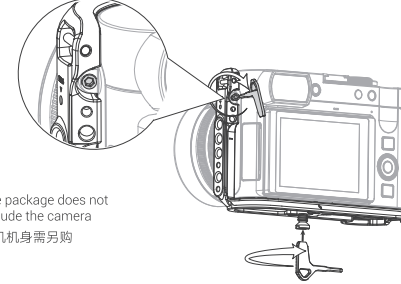

* The package does not include the camera
* 相机机身需另购

Step 3: Install the handgrip supports.

第三步: 安装手握支撑。

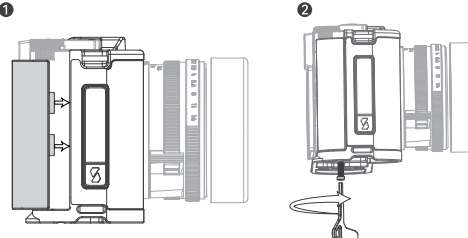

HDMI & USB-C Cable Clamp Installation Instruction
HDMI & USB-C 线夹安装步骤

Step 1: Remove the M3 screw on the inner side of the cable clamp, and secure the cable clamp to the cage.

第一步: 取下线夹内侧的M3 螺丝, 将线夹和拓展框锁紧固定。

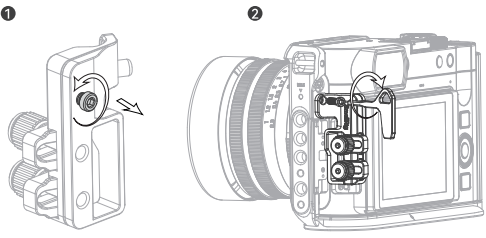

Step 2: Insert the HDMI & USB-C cable.

第二步: 插入HDMI & USB-C线。

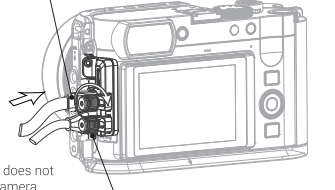

* The package does not include the camera
* 相机机身需另购

Step 3: Tighten the thumbscrews to secure the cable.

第三步: 拧紧手拧螺丝固定线材。

Cold Shoe Mount Installation Instruction / 冷靴安装步骤

Attach the cold shoe on the top of the cage or to the built-in 1/4"-20 locating holes on the left side of the cage.

可将冷靴安装至拓展框顶部或左侧有内置1/4"-20 定位螺孔处。

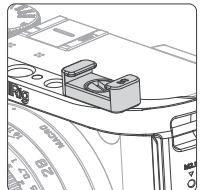
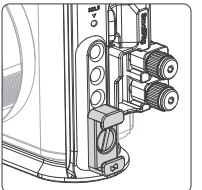



执行标准: GB/T 26572-2011

CE RoHS 合格证 已检验

MADE IN CHINA 中国制造

LQ-P1301-18





技术要求 (包装物料)	单位	mm	页码	1/1	公差 ±1	MODEL (成品号)	4567	LEQI 乐其 SmallRig 斯莫格		文案审核	Vi 审核
	纸张厚度标准:					PART_NO. (物料编号)	LQ-P1301-18	包装设计	认证工程师	ID设计师	产品经理
	铜版纸类印刷品: 纸张克重依据印刷行业行业标准 坑纹纸类印刷品: 破裂强度及边压强度依据印刷行业行业标准					PART_NAME (零件名称)	操作指引	包装复核	质量工程师	结构设计师	产品线总监

1.材料:所有材料要求符合RoHS 2.0环保要求
2.珍珠棉类及含有胶水材料需满足质量验收要求:
低温存储 -20°C±2°C 24h
高温高湿 70±2°C 90%±5% 24h
不溢胶,不自然分层,测试后产品无残胶
3.工艺:模切整齐,无划痕;覆膜无尘,无气泡;烫印工整
4.印刷:印刷清晰,无污点,无脏污
5.公差:彩盒±1mm;物流箱±10mm
6.外观:外观要求参考承认样,提供《样品承认书》